

**Pedigree Worksheet**

Name \_\_\_\_\_

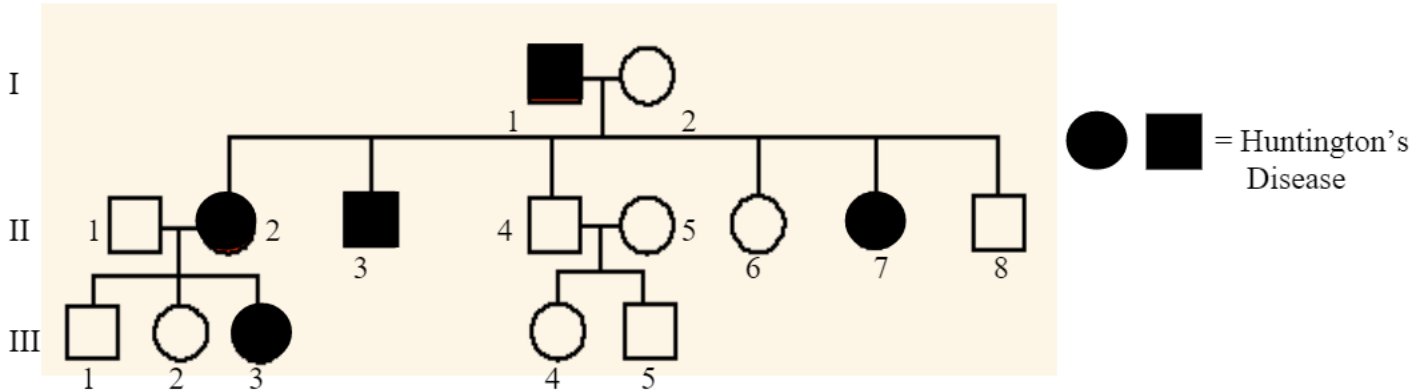

- Which members of the family above are afflicted with Huntington's Disease? \_\_\_\_\_
- There are no carriers for Huntington's Disease- you either have it or you don't. With this in mind, is Huntington's disease caused by a dominant or recessive trait? \_\_\_\_\_
- How many children did individuals I-1 and I-2 have? \_\_\_\_\_
- How many girls did II-1 and II-2 have? \_\_\_\_\_ How many have Huntington's Disease? \_\_\_\_\_
- How are individuals III-2 and II-4 related? \_\_\_\_\_ I-2 and III-5? \_\_\_\_\_

6. The pedigree to the right shows a family's pedigree for Hitchhiker's Thumb. Is this trait dominant or recessive? \_\_\_\_\_

7. How do you know? \_\_\_\_\_

8. How are individuals III-1 and III-2 related? \_\_\_\_\_

9. How would you name the 2 individuals that have hitchhiker's thumb? \_\_\_\_\_

10. Name the 2 individuals that were carriers of hitchhiker's thumb. \_\_\_\_\_

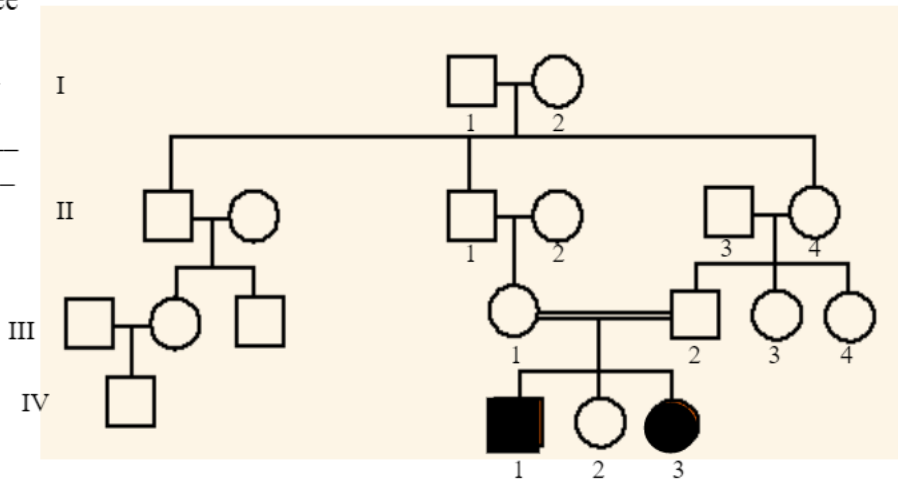

11. Is it possible for individual IV-2 to be a carrier? \_\_\_\_\_ Why? \_\_\_\_\_

12. The pedigree to the right shows a family's pedigree for colorblindness. Which sex can be carriers of colorblindness and not have it? \_\_\_\_\_

13. With this in mind, what kind of trait is colorblindness (use your notes)? \_\_\_\_\_

14. Why does individual IV-7 have colorblindness? \_\_\_\_\_

15. Why do all the daughters in generation II carry the colorblind gene? \_\_\_\_\_

16. Name 2 IV generation colorblind males. \_\_\_\_\_

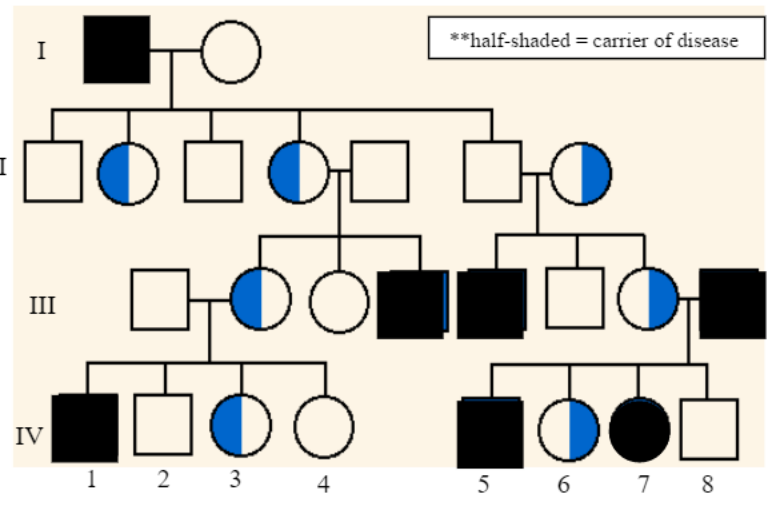

**Genetics Pedigree Worksheet**

A pedigree is a chart of a person's ancestors that is used to analyze genetic inheritance of certain traits – especially diseases. The symbols used for a pedigree are:

- |                      |                    |
|----------------------|--------------------|
| ○ female, unaffected | □ male, unaffected |
| ● female, affected   | ■ male, affected   |

- Siblings are placed in birth order from left to right and are labeled with numbers.
- Each generation is labeled with a Roman numeral.
  - Example: we would name an individual II-3 if he/she was in the second generation and the 3<sup>rd</sup> child born

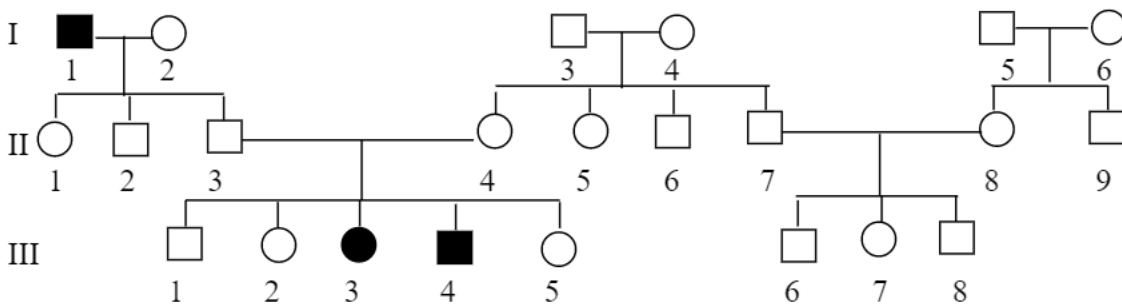

Try to identify the genotypes of the following individuals using the pedigree above.  
(homozygous dominant, homozygous recessive, heterozygous)

- |                |               |
|----------------|---------------|
| • III-3: _____ | • I-1: _____  |
| • II-1: _____  | • II-4: _____ |

1. Is this trait dominant or recessive? Explain your answer.

\_\_\_\_\_

\_\_\_\_\_

\_\_\_\_\_

2. How can you know for sure that individuals II-3 and II-4 are heterozygous?

\_\_\_\_\_

\_\_\_\_\_

3. Brown eyes are a dominant eye-color allele and blue eyes are recessive. A brown-eyed woman whose father had blue eyes and whose mother had brown eyes marries a brown-eyed man whose parents are also brown-eyed. They have a son who is blue-eyed. Please draw a pedigree showing all four grandparents, the two parents, and the son. Indicate which individuals you are certain of their genotype and where there are more than one possibilities.

# Pedigree Worksheet **KEY**

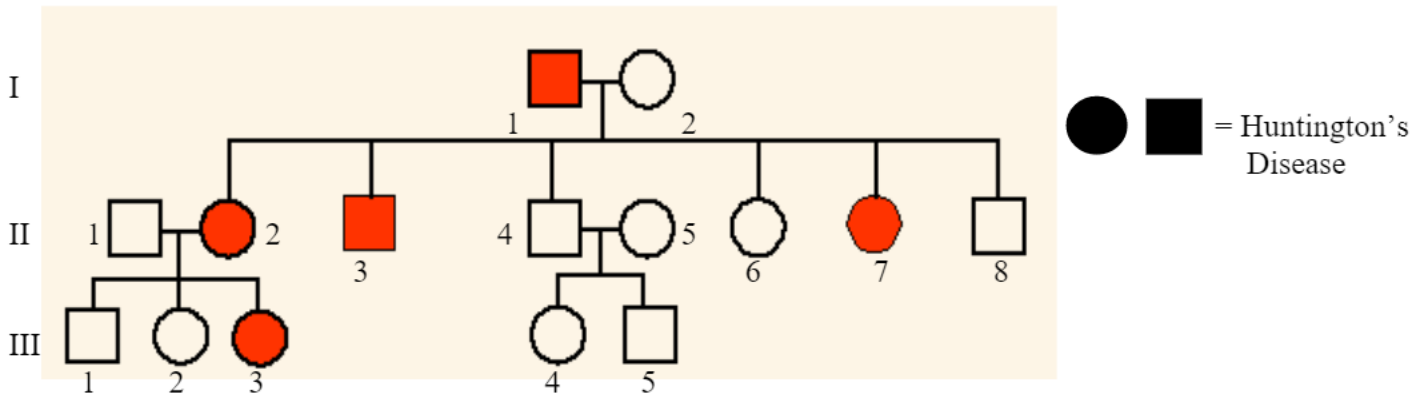

1. Which members of the family above are afflicted with Huntington's Disease? **I1, II2, II3, II7, III3**
2. There are no carriers for Huntington's Disease- you either have it or you don't. With this in mind, is Huntington's disease caused by a dominant or recessive trait? **Dominant**
3. How many children did individuals I-1 and I-2 have? **6**
4. How many girls did II-1 and II-2 have? **2** How many have Huntington's Disease? **1 or 5**
5. How are individuals III-2 and II-4 related? **Uncle/Niece** I-2 and III-5? **Grandma/Grandson**

6. The pedigree to the right shows a family's pedigree for Hitchhiker's Thumb. Is this trait dominant or recessive? **Recessive**

7. How do you know? **III1 and III2 do not have it but their children do.**

8. How are individuals III-1 and III-2 related? **Cousins/Marriage**

9. How would you name the 2 individuals that have hitchhiker's thumb? **IV1 and IV3**

10. Name the 2 individuals that were carriers of hitchhiker's thumb. **III1 and III2**

11. Is it possible for individual IV-2 to be a carrier? **Yes** Why? **b/c parents were heterozygous**

12. The pedigree to the right shows a family's pedigree for colorblindness. Which sex can be carriers of colorblindness and not have it? **Females**

13. With this in mind, what kind of trait is colorblindness (use your notes)? **Sexlinked/recessive**

14. Why does individual IV-7 have colorblindness? **b/c mom was a carrier and dad was affected**

15. Why do all the daughters in generation II carry the colorblind gene? **b/c dad was affected and its on the X**

16. Name 2 IV generation colorblind males. **IV1, IV5**

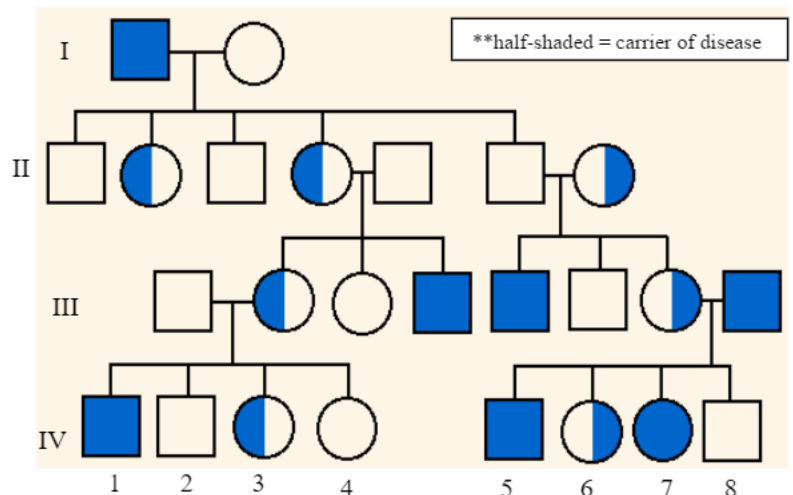
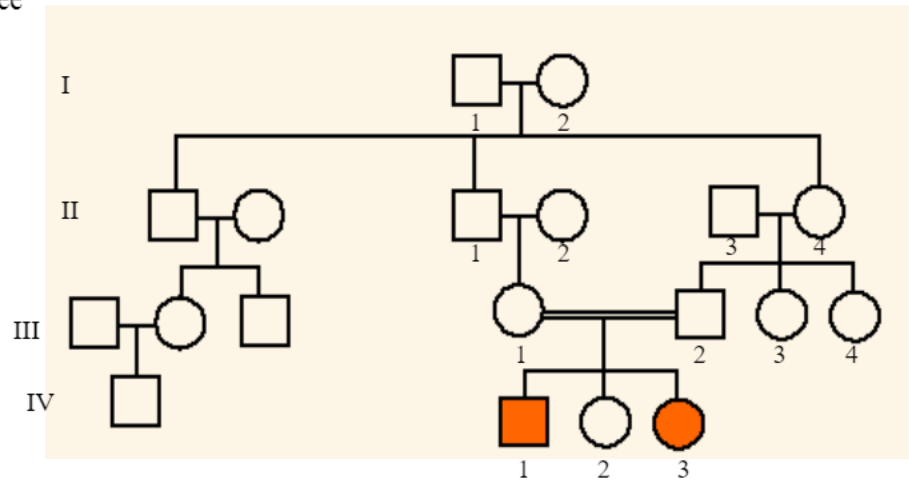

**Pedigree Worksheet KEY**  
**Genetics Pedigree Worksheet**

A pedigree is a chart of a person's ancestors that is used to analyze genetic inheritance of certain traits – especially diseases. The symbols used for a pedigree are:

- |                      |                    |
|----------------------|--------------------|
| ○ female, unaffected | □ male, unaffected |
| ● female, affected   | ■ male, affected   |

- Siblings are placed in birth order from left to right and are labeled with numbers.
- Each generation is labeled with a Roman numeral.
  - Example: we would name an individual II-3 if he/she was in the second generation and the 3<sup>rd</sup> child born

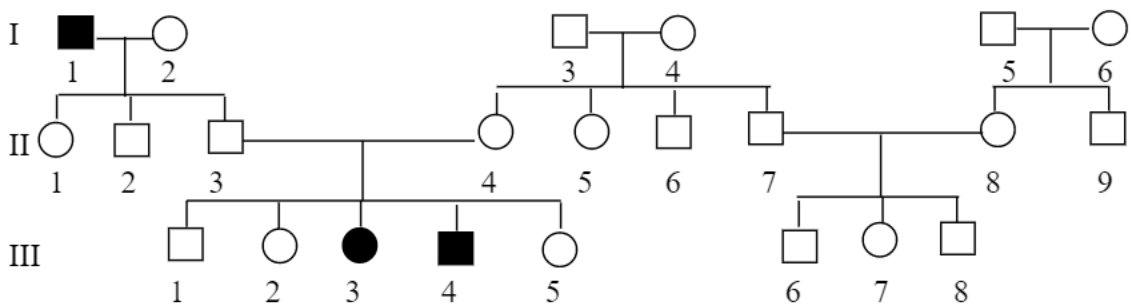

Try to identify the genotypes of the following individuals using the pedigree above.  
 (homozygous dominant, homozygous recessive, heterozygous)

- III-3: **Homozygous recessive**
- II-1: **Heterozygous**
- I-1: **Homozygous recessive**
- II-4: **Heterozygous**

1. Is this trait dominant or recessive? Explain your answer.

**It is a recessive trait because generation II does not have the disease and Generations I and II do have it.**

2. How can you know for sure that individuals II-3 and II-4 are heterozygous?

**Because their offspring have the disease so they are both carriers of it.**

3. Brown eyes are a dominant eye-color allele and blue eyes are recessive. A brown-eyed woman whose father had blue eyes and whose mother had brown eyes marries a brown-eyed man whose parents are also brown-eyed. They have a son who is blue-eyed. Please draw a pedigree showing all four grandparents, the two parents, and the son. Indicate which individuals you are certain of their genotype and where there are more than one possibilities.